

Surfbee RTK Manual



surfbee.io

V 1.2.2026

Table of Content

1. Introduction to Real-Time Kinematic RTK	02
Overview of RTK technology, its main correction methods, and when to use RTK for centimeter-level accuracy.	
2. Equipment Overview	03
Lists the components included in the Surfbee RTK Base Station kit and their functions.	
3. RTK Base Station Manual - Step by step	05
Introduces the manual's purpose and its What > Where > How structure.	
4. Assembly and Mounting	06
Covers assembling the RTK base, installing antennas, and powering the system on/off.	
5. Set Up Your Controller and Turn On	08
Explains how to power the controller on/off, connect it to an external battery, interpret LED status signals, and ensure it receives data from the RTK Base.	
6. Troubleshooting	09
Outlines key troubleshooting steps, including resets, app checks, and verifying cables and antennas.	
7. Software Configuration	12
Explains how to configure RTK communication in the Surfbee App using Auto-Connect or Manual NTRIP settings specifically for base station setup.	
8. Safety	17
Lists essential safety guidelines for proper and secure equipment use.	

1. Introduction to Real-Time Kinematic | RTK

Real-Time Kinematic (RTK) is a ground-based GNSS correction technique that improves standard GPS/GNSS accuracy by comparing measurements between a fixed reference station and a moving receiver.

By using the highly stable carrier-phase of GNSS signals and applying differential corrections in real time, RTK reduces positioning errors from meters down to centimeter- or decimeter-level, depending on the correction method used.

In the Surfbee system, these corrections can be delivered in several ways depending on connectivity, range, and accuracy needs.

Surfbee's vessels support 3 types of RTK corrections protocols:

- **RTK Base Station:** This method uses a physical Surfbee RTK Base Station equipped with a LoRa radio. The base station transmits correction data directly to the Surfbee transmitter, which then forwards it to the vessel. The vessel's position is relative to the base station and not absolute. Corrections can also be output through the Multiport. Ideal for small- to medium-sized survey areas where the distance between base and rover is under 10–20 km.
- **Network RTK (NTRIP):** NTRIP uses an internet connection from the Surfbee transmitter to receive correction data from an NTRIP service. The vessel receives these corrections over the network and can also output them through the Multiport. Recommended when operating across wide areas and where you have reliable internet connection.
- **Surfbee RTK Direct (HAS System):** Surfbee RTK Direct unlocks the vessel's ability to receive RTK-like corrections via HAS (High Accuracy System) without any external NTRIP services or hardware. This upgrade enhances GNSS accuracy and achieves PPP/SSR-style decimetre accuracy similar to an RTK float state, making it ideal where absolute, survey-grade accuracy is not critical but improved positioning is required. This is a GNSS chip-level configuration; no extra hardware and no field setup are required, but system typically needs about 5 minutes to converge and start applying corrections.

When should you use RTK?

- When you require accuracy for surveying, mapping, or hydrographic work.
- When working in open environments with a clear view of the sky.
- When GPS-only accuracy (typically 2–5 meters) is insufficient for your application.



RTK ensures your Surfbee system provides consistent, precise results for missions that demand accuracy and reliability.

Because the maps displayed in the Surfbee app rely on online map services, their alignment and absolute accuracy can vary depending on the region. These maps are intended for visual reference only.

Our commitment is to the GNSS data output through the Multiport, which reflects the true RTK-corrected positioning of your vessel, regardless of how the background map appears.

2. Equipment Overview:

Your Surfbee RTK Base Station package includes the following components:

- **RTK Base Station Case:** Waterproof case that houses and protects the RTK equipment.
- **GNSS Antenna:** Captures satellite signals for high-precision data.
- **GNSS Support:** Secures the GNSS antenna steady and aligned.
- **RTK Antenna:** A communication that sends correction data to your USV.
- **LoRa RTK Receiver Radio:** Connects and configures the base station. Requires an external power bank such as a USB-C power bank (batteries not included).
- **USB-C power cable:** Connects to your power bank to provide power to the base station.

1 RTK Base Station

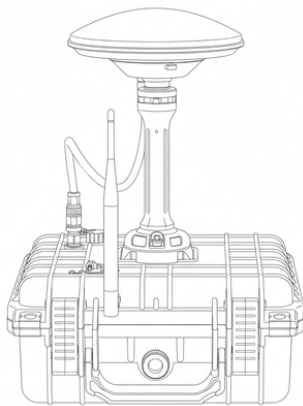

Closed



Open

2 Surfbee APP

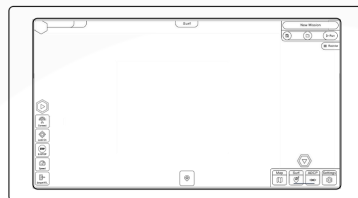

3 7. LoRa RTK Receiver Radio

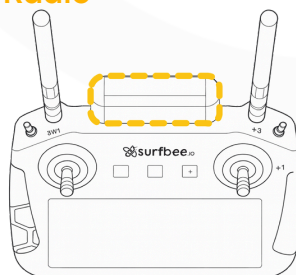
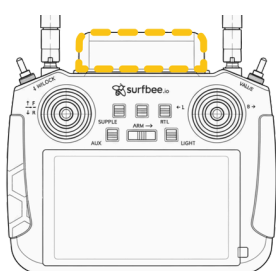

RTK Base Station



1. GNSS Antenna

Compact outdoor antenna that receives GNSS signals and feeds them to the case for positioning.

2. Antenna Extension Mount

A universal extension mount used to elevate and position the GNSS antenna for improved signal reception.

3. GNSS Connection Cable

An external high-precision GNSS antenna used to receive satellite positioning signals and feed them to the case through the CAT7 connection cable.

4. RTK Base Station Case

Durable waterproof hard-case for housing the GNSS receiver and electronics — tough enough for field use, protecting equipment from dust, water, impact and rough handling.

5. RTK MHz Antenna

A telemetry antenna that connects to the receiver in the Surfbee transmitter, enabling reliable wireless communication with the base station.

6. Surfbee Transmitter

A handheld control unit used to operate and navigate the vessel. This transmitter is part of the vessel's system and is not included with the RTK base-station kit.

7. LoRa RTK Receiver Radio

A plug-in LoRa radio module that connects to the Surfbee vessel-control transmitter, enabling it to receive RTK correction data from the base station.

3. RTK Base Station Manual - Step by step

1 Introduction

Welcome to the Surfbee RTK Base Station Manual. This guide provides clear, step-by-step instructions to help you set up, operate, and maintain your RTK Base Station safely and efficiently. Each section follows the **What > Where > How** format for easier understanding and quick reference in the field.

2 Using Your RTK Station

1. Setup the RTK Base Station > 2. Turn on the controller

- Connect the RTK Base Station to an external portable battery (USB power bank). The station will automatically power on when plugged in.
- Turn on the controller
- Check that the controller is receiving data — the LED indicator should show active transmission.

Tip:

The RTK Base does not include internal batteries. Use any USB power bank with sufficient output to operate the system.

4. Assembly and Mounting

SET UP THE BASE > MOUNT THE GNSS ANTENNA > MOUNT THE RTK ANTENNA > POWER ON THE RTK BASE > POWER OFF THE RTK BASE

1 Set up the Base

1.1 Place the case on a **flat and stable surface** with clear sky visibility.

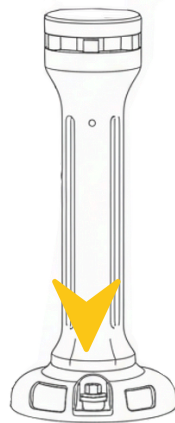
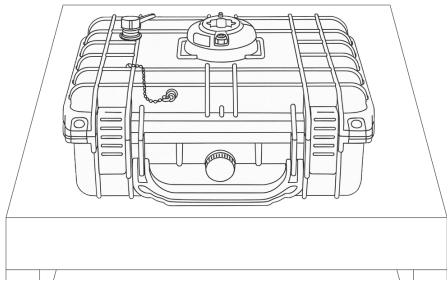

1.2 Connect the Extender to the base station

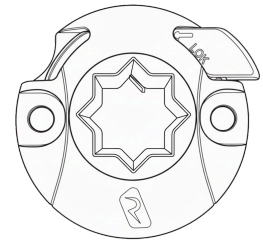

1.3 Lock the extender to securely hold in position



SET UP THE BASE > **MOUNT THE GNSS ANTENNA** > MOUNT THE 915 MHZ ANTENNA > POWER ON THE RTK BASE > POWER OFF THE RTK BASE

2 Mount the GNSS Antenna

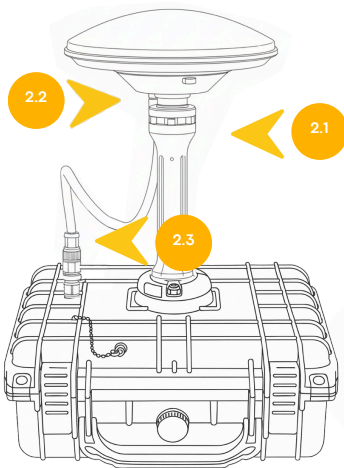

2.1. Insert the **GNSS antenna to the extender.**

2.2. Connect the GNSS cable to your GNSS Antenna

2.3. Connect the cable to the **rear port.**

Use the **lock/unlock safety mechanism** to secure all connections. Push forward to unlock, then insert the connector and release to lock.

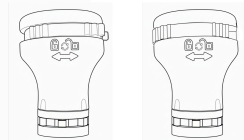

⚠ Important Note:

Always unlock before connecting or disconnecting any cable. Unlock by slighting forward, insert or remove the plug, then release to lock securely.

ASSEMBLY AND MOUNTING

SET UP THE BASE > MOUNT THE GNSS ANTENNA > **MOUNT THE RTK ANTENNA** > POWER ON THE RTK BASE > POWER OFF THE RTK BASE

3 Mount the RTK Antenna

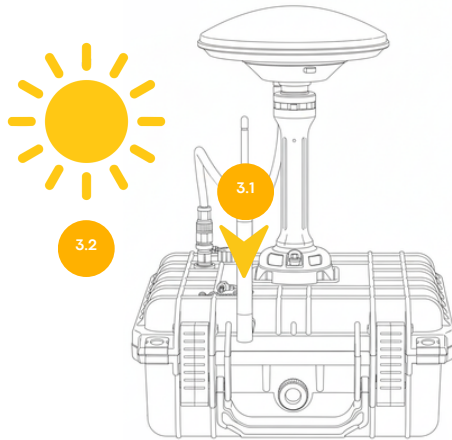

3.1. Plug the antenna into the upper-right port on the case.

3.2. Ensure it has a **clear view of the sky** for best transmission performance.

SET UP THE BASE > MOUNT THE GNSS ANTENNA > MOUNT THE RTK ANTENNA > **POWER ON THE RTK BASE** > POWER OFF THE RTK BASE

4 Power On the RTK base

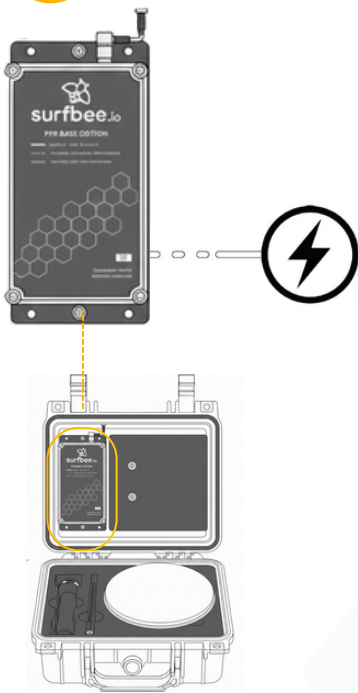

4.1

Power on **only after the full assembly is complete.**

4.2

Plug the power bank into the station to activate it automatically.



Important Note: Power Supply Requirements

This RTK Base Station does not include a built-in battery. You may power the unit using any standard USB-C power source, such as a power bank, wall adapter, or other compatible USB-C power supply. There are no specific power requirements, as long as the source can provide stable USB-C output.

You may use the USB-C cable provided with the product, or any other USB-C cable of your choice.

What will happen in the backend:

After 60–120 seconds of survey-in, the RTK Base station completes initialisation and begins transmitting RTCM correction data via the radio port. When used together with your USV and Controller, the base station can deliver up to 14 mm (about 0.55 in) relative positioning precision between the vessel and the base.

5. Set Up Your Transmitter to start receiving RTK corrections

SET UP YOUR TRANSMITTER > LED LIGH > TURN OFF

1 Power on the Controller

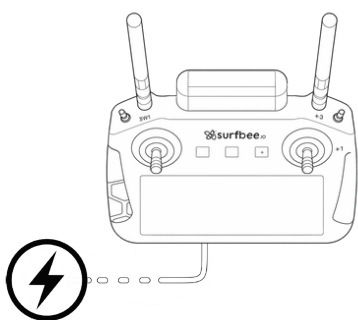

1.1 Make sure you have your transmitter with enough battery

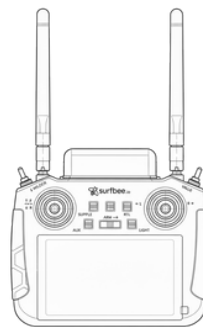

1.2 Observe the LED indicators to confirm power and connection.

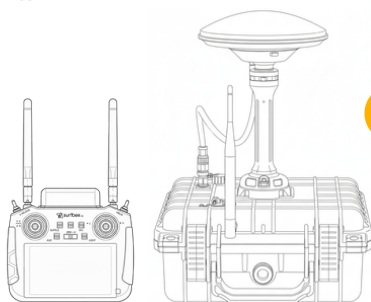

1.3 Ensure the controller is connected to the RTK Base and receiving data.



Important Note:

Check the LED light in the next page to confirm if your RTK base station is connected to your transmitter

POWER ON THE CONTROLLER > **LED LIGH** > TURN OFF

2 LED light

Once you power your base station, a LED light will automatically turn on. Here's what you need to know:



Solid White Your base station is powered on and is starting to look for the radio to automatically pair.

Slow Flash Your base station is paired with the transmitter, but there's still no data is being transmitted.

Fast Flash Actively transmitting data to your transmitter.



Tip:

Make sure the RTK Base is turned on so the controller receives data. If you lose connection, restart the controller or check your antenna connections.

6. Troubleshooting

RESET AND POWER CHECK > AUTO CONNECT RESET > CABLES AND ANTENNAS

1 Reset and Power Check

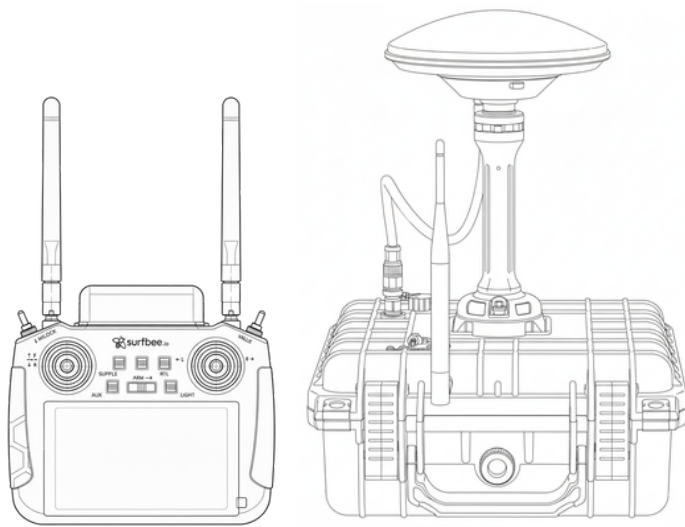

RESET AND POWER CHECK > AUTO CONNECT RESET > CABLES AND ANTENNAS

2 Auto Connect Reset

2.1 Open the Surfbee App on your device.



TROUBLESHOOTING

2.2 Go to Settings → NTRIP Options



2.3 Turn off the Auto-Connect.

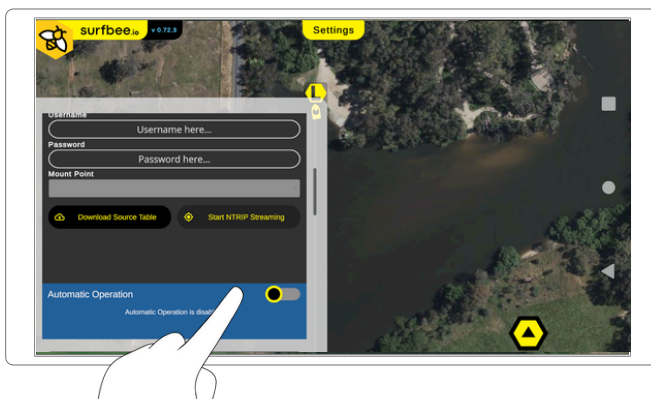

2.4 On NTRIP options, select configure

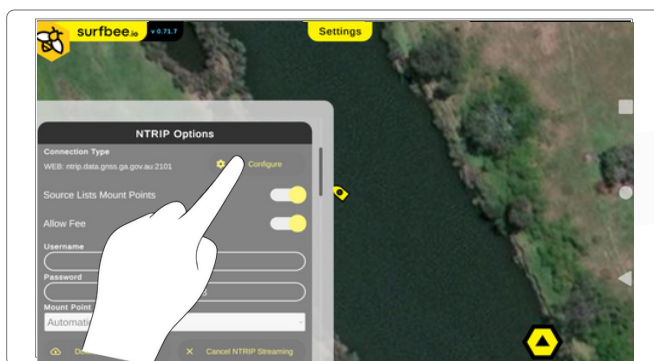

TROUBLESHOOTING

- 2.5 Confirm that you have correctly selected the correct port ("COM Port"), device ("/dev/bus/usb/001/003") and baud rate ("57600") as below, pressing save:

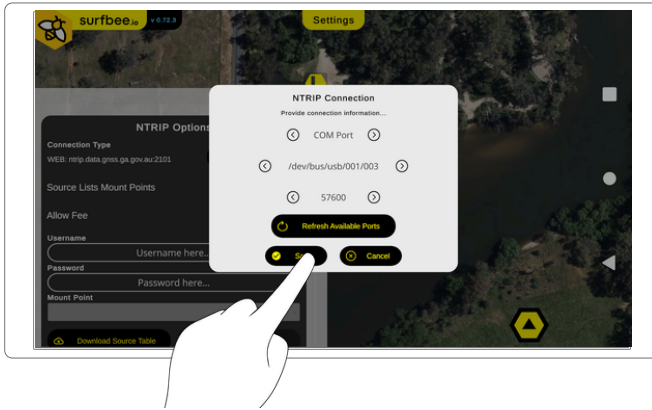

- 2.6 Press Automatic Operation to start streaming:

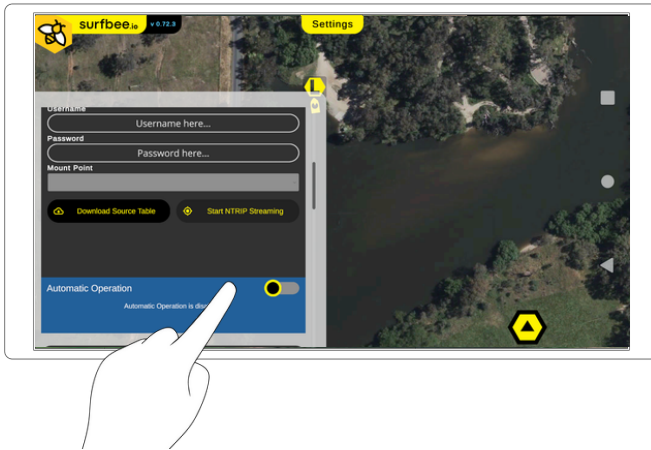

3 Cables and Antennas

RESET AND POWER CHECK > AUTO CONNECT RESET > **CABLES AND ANTENNAS**

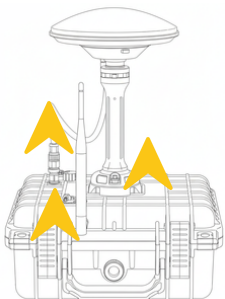

- 3.1 Disconnect all cables and antennas.

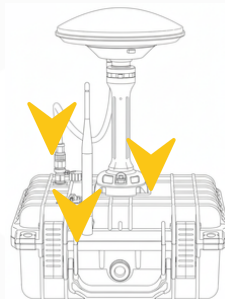

3.2

Tip:

If you still having any issue change to manual software configuration.

7. SOFTWARE CONFIGURATION

AUTO-CONNECT > NTRIP MANUAL CONNECTION - ONLY FOR RTK BASE STATION SETUP.

1 Auto-connect

If you ordered your RTK Base Station with your vessel, the auto-connect will be ready from factory

1.1 Open the Surfbee App on your device.



1.2 Slide the arrow located in the right side of the screen

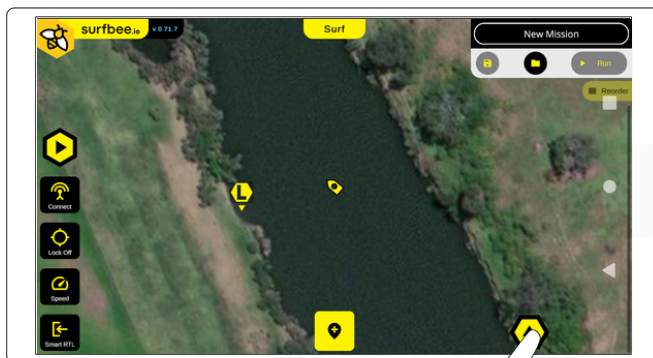

SOFTWARE CONFIGURATION

1.3 Go to Settings



1.4 Under NTRIP Options, scroll down to auto-connect

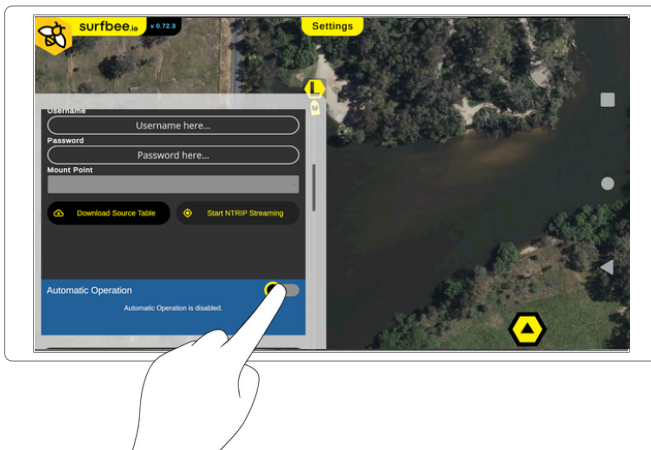

1.5 By selecting Auto-Connect your vessel will automatically search for your base station (if powered on and nearby) and connect to it:

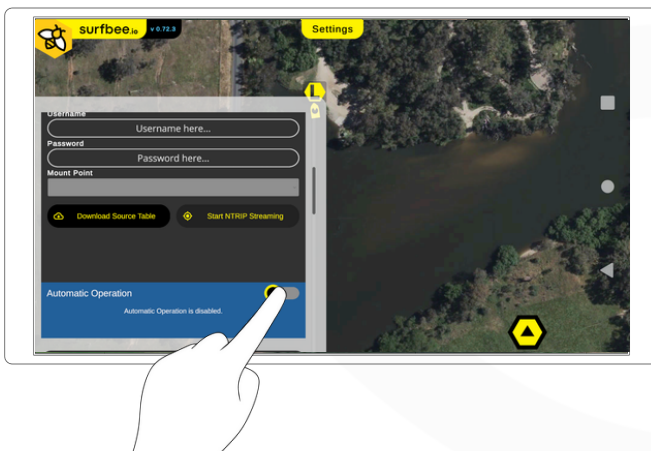

2 Manual Connection |

If you have any problems connecting, or if you have used NTRIP and need to change back to the base station, follow these steps

2.1 Open the Surfbee App on your device.



2.2 Slide the arrow located in the right side of the screen

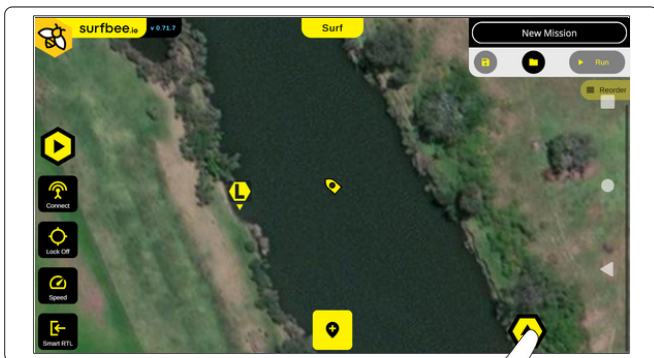

2.3 Go to **Settings**



SOFTWARE CONFIGURATION

2.4 Under NTRIP Options, select configure



2.5 Use the arrows to Select: "COM Port", "/dev/bus/usb/001/003" and "57600" as the image shows

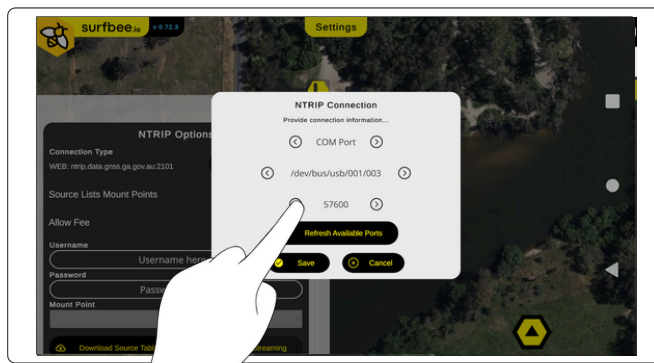

Tip:

Use the surfbee app Manual for more information regarding NTRIP service

2.6 Press save

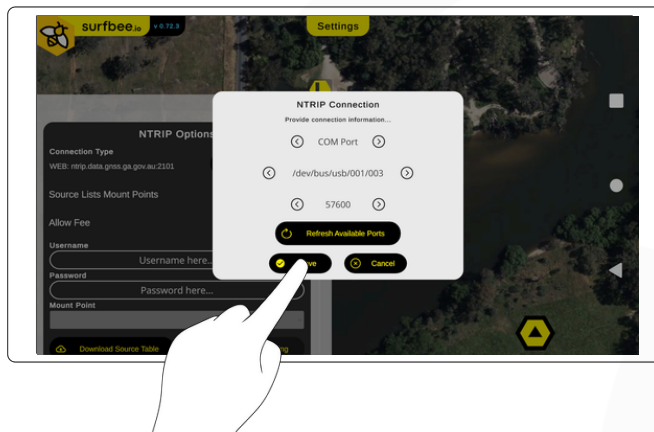

SOFTWARE CONFIGURATION

- 2.7 Now scroll down and select Auto-connect. You will start receiving corrections immediately.



Important Note:





The NTRIP Connection COM PORT is only for RTK Base Station setup. If you wish to use NTRIP services, select http instead of COM Port or check the Surfbee App Manual

8. Safety

What: Safety and Usage Guidelines

Where: All equipment

Steps:

-  Use only certified power banks and accessories.
-  Power on only after the assembly is complete.
-  Operate outdoors with a clear view of the sky.
-  Keep all components dry and protected from heat.

For questions or support, contact support@surfbee.io
we'll be happy to assist you.